

EM converterLED BASIC MH/LiFePO4 250 V

BASIC version

**Product description**

- _ Self contained emergency lighting LED driver for manual testing
- _ For LED modules with a forward voltage of 50 – 250 V
- _ Low profile casing (21 x 30 mm cross-section)
- _ For luminaire installation
- _ Nominal lifetime up to 100,000 h
- _ 5 years guarantee

Properties

- _ Non maintained operation
- _ 1 or 3 h rated duration
- _ Operating time selectable with plug (duration link)
- _ Compatible with all dimmable and non-dimmable constant current LED driver (see data sheet, LED driver compatibility)
- _ 3-pole technology: 2-pole LED module changeover and delayed power switching for the LED driver
- _ Automatic shutdown of output if LED load is out of range
- _ Constant power output
- _ Maximum light output for all LED modules
- _ Electronic charge system
- _ Deep discharge protection
- _ Short-circuit-proof battery connection
- _ Polarity reversal protection for battery provided by 3-pole connector
- _ Automatic detection of the connected battery technology (NiMH or LiFePO4 batteries)

Batteries

- _ High-temperature cells
- _ NiMH or LiFePO4 batteries
- _ LA or 18650 cells
- _ 4-year design life for NiMH batteries
- _ 1 years guarantee for NiMH batteries
- _ 4 – 8 years design life for LiFePO4 batteries
- _ 3 years guarantee for LiFePO4 batteries
- _ For battery compatibility refer to datasheet, battery selection

Website

<http://www.tridonic.com/89800709>

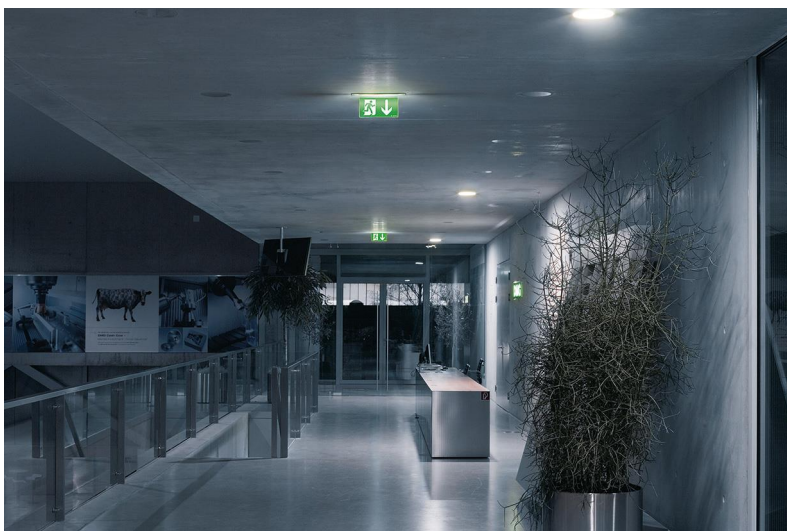

EM converterLED BASIC MH/LiFePO4 250 V

BASIC version

The complete data sheet for this product is available in the Downloads section.

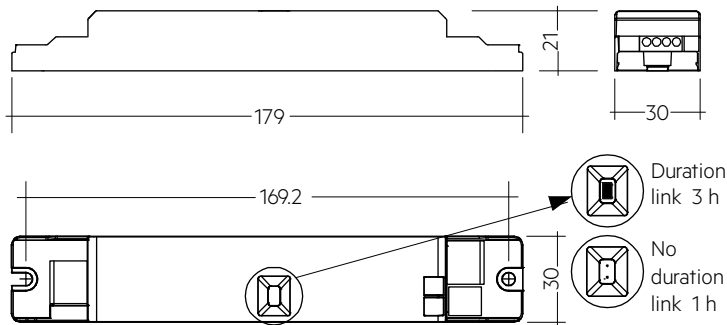

Note: Supply of control gear with duration link in 3 hours position. Remove duration link for duration of 1 h. Duration link must be set before battery and mains connection.

Ordering data

Type [®]	Article number	Rated duration	Packaging, carton	Packaging, pallet	Weight per pc.	Dimensions L x W x H
EM converterLED BASIC 202A MH/LiFePO4 250	89800709	1/3 h	10 pc(s).	1,600 pc(s).	0.07 kg	179 x 30 x 21 mm

Technical data

Rated supply voltage	220 – 240 V
AC voltage range	198 – 264 V
Mains frequency	50 / 60 Hz
Forward voltage range LED module	50 – 250 V
Output current	Refer to data sheet
Starting time	< 0.5 s from detection of emergency event
Overvoltage protection	320 V (for 48 h)
U-OUT (including open- / short-circuit and double load)	280 V
Max. open circuit voltage	280 V
Battery charging time ^{①②}	24 h
Ambient temperature <i>t</i> _a	-5 ... +55 °C
Max. casing temperature <i>t</i> _c	75 °C
Mains voltage changeover threshold	According to EN 60598-2-22
Mains surge capability (between L - N)	1 kV
Mains surge capability (between L/N - PE)	2 kV
Type of protection	IP20
Lifetime	up to 100,000 h
Guarantee	5 Year(s)
Dimensions L x W x H	179 x 30 x 21 mm

Approval marks



Standards

according to EN 50172, according to EN 60598-2-22, EN 61347-1, EN 61347-2-13, EN 61347-2-7, EN 55015, EN 61000-3-2, EN 61000-3-3, EN 61547, EN 60068-2-64, EN 60068-2-29, EN 60068-2-30, EN 62384

Specific technical data

Type	Battery technology	Rated duration	Typ. λ (at 230 V, 50 HZ)	Typ. output power P emergency	Mains current in charging operation			Mains power in charging operation		
					Initial charge	Fast recharge	Trickle charge ^①	Initial charge	Fast recharge	Trickle charge ^①
EM converterLED BASIC 202A MH/LiFePO4 250	NiMH	1 / -1 h	0.60C	2.3 W	17 mA	17 mA	17 / 12 mA	2.4 W	2.4 W	2.4 / 1.4 W
EM converterLED BASIC 202A MH/LiFePO4 250	NiMH	3 / -1 h	0.60C	2.3 W	18 mA	18 mA	18 / 12 mA	2.6 W	2.6 W	2.6 / 1.4 W
EM converterLED BASIC 202A MH/LiFePO4 250	LiFePO4	1 / -1 h	0.60C	2.3 W	17 mA	17 mA	17 / 12 mA	2.1 W	2.1 W	2.1 / 1.4 W
EM converterLED BASIC 202A MH/LiFePO4 250	LiFePO4	3 / -1 h	0.60C	2.3 W	20 mA	20 mA	20 / 12 mA	2.9 W	2.9 W	2.9 / 1.4 W

① 16 h battery charging time for 2 h emergency lighting function according to AS 2293.

② 12 h battery charging time for 2 h emergency lighting function when used with LiFePO4 batteries.

③ EM = Emergency

④ In case of NiMH batteries: Intermittent charge is used. Value 1 is for 4 min. charge on / Value 2 is for 16 min. charge off. In case of LiFePO4 batteries voltage dependent constant current charging is used.