

25W Constant Current -CS Series

CS-25-XXX LB



■ Approve



■ Features

- Class II, SELV, Built-in
- Input Voltage 220-240VAC
- Protections: SCP/OLP/OVP
- Power Factor >0.9
- Efficiency ≥86%
- 3 years warranty

■ Applications(Typ.)

- Spot light
- Wall light
- COB light

■ Description

CS-25-XXX LB is a 21-25W constant current LED driver that operates from 176-264Vac input with 500/550/600mA output current. With it's compact dimensions from $\Phi 55 \times 26\text{mm}$ it is easy to integrate in spot light, wall light and COB light products. To ensure trouble-free operation, protection is provided against output short circuit and over Load.

■ Model code

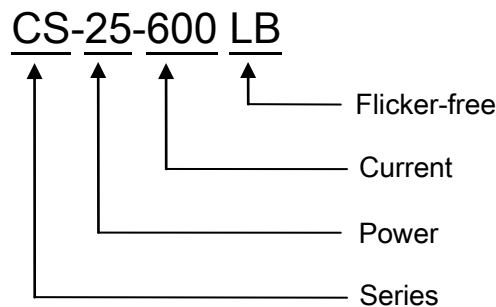

25W Constant Current -CS Series

CS-25-XXX LB

■ Specification

Input	Rated input voltage	220-240VAC		
	Range of input voltage	176-264VAC		
	DC input voltage	176-280V		
	Frequency(Hz)	0/50/60 Hz		
	Power Factor	> 0.9@Full Load,240VAC		
	Input Current max @Full Load,176VAC	0.16A MAX.	0.18A MAX.	0.19A MAX.
	Start-up time	< 0.5S		
	Unload Power Consumption	≤0.5W		
	Inrush Current	25A Max.		
	THD	< 10%@Full Load,240VAC		
	Leakage Current	< 0.7mA(240VAC)		
Output	Constant Current *Note 3	500mA	550mA	600mA
	Unload voltage Max.	50VDC	50VDC	50VDC
	Voltage Range(VDC)	28-43VDC	28-42VDC	28-42VDC
	Rated power	21.5W Max.	23.1W Max.	25.2W Max.
	Current Accuracy	±5%@220-240VAC		
	Voltage Regulation	±5% @Full Load, 220-240VAC		
	Load Regulation	±5%@220-240VAC		
	Hold-up Time	1s max.@Full Load		
	Ripple& Noise *Note.2	≤±3%		
	Efficiency(Typ.)	≥86%		
Protecti- on	Over Load Protection	103-120% Protection type: Auto Resume		
	Over Voltage Protection	> 50VDC Protection type: Auto Resume		
	Short circuit Protection	Protection type: Auto Resume		
Environ- ment	Operating Temperature	-20°C...+60°C		
	tc	90°C		
	Storage Temperature	-25°C...+60°C		
	Life time	> 30,000h@60°C		
	Humidity	20%-90%RH		
Others	Dimension	Φ55X26(DXH)mm		
Safety & EMC	Safety standards	EN 61347-1; EN61347-2-13; EN62384		
	Withstand voltage	Input-Output : 3750V/5mA/1min		
	Isolation resistance	Input-Output : ≥4MΩ@500VDC		
	EMI	EN55015; EN61000-3-2 Class C; EN61000-3-3		
	EMS	EN 61547; EN 61000-4-2; EN 61000-4-5 —1000V;		
Note	1.All parameters NOT specially mentioned are measured at 240VAC input , full load and 25°C of ambient temperature. 2.Ripple & Noise are measured at 20MHz of bandwidth by using a 300mm twisted pair-wire terminated with a 0.1uF & 47 uF parallel capacitor. 3.Output current can be from 500mA to 600mA and increasing in multiples of 50mA. Please see Model list below and contact EAGLERISE for details.			

25W Constant Current -CS Series

CS-25-XXX LB

Model list

NO.	Model number	Input			Output			Max.Prated(W)
		Voltage (VAC)	Current (A)	Frequency (Hz)	Constant current (mA)	Normal working voltage (VDC)	No load working voltage (VDC)	
1	CS-25-500 LB	220-240	0.16	50/60	500	28-43	50	21.5
2	CS-25-550 LB	220-240	0.18	50/60	550	28-42	50	23.1
3	CS-25-600 LB	220-240	0.19	50/60	600	28-42	50	25.2

Wiring diagram

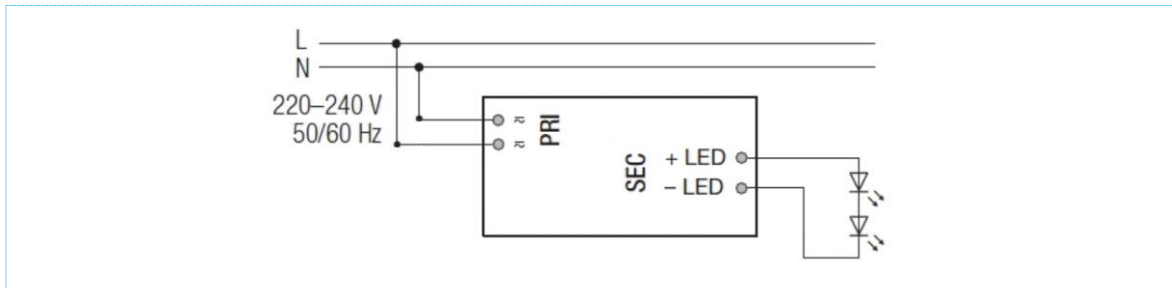

2D diagram

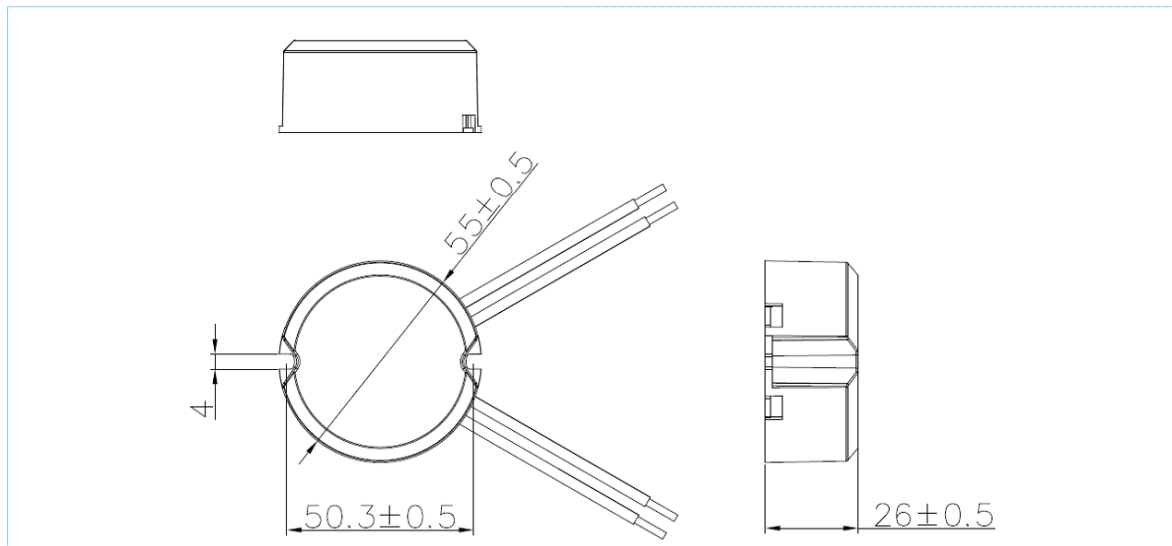

25W Constant Current -CS Series

CS-25-XXX LB

■Curve for CS-25-600 LB

Lifetime vs. Ambient Temperature Curve

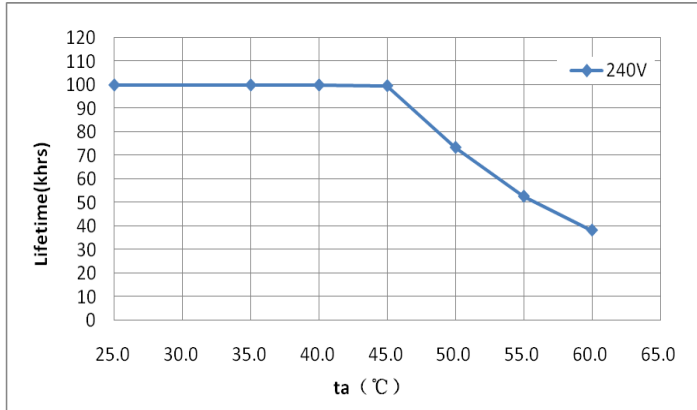

Efficiency vs. Load

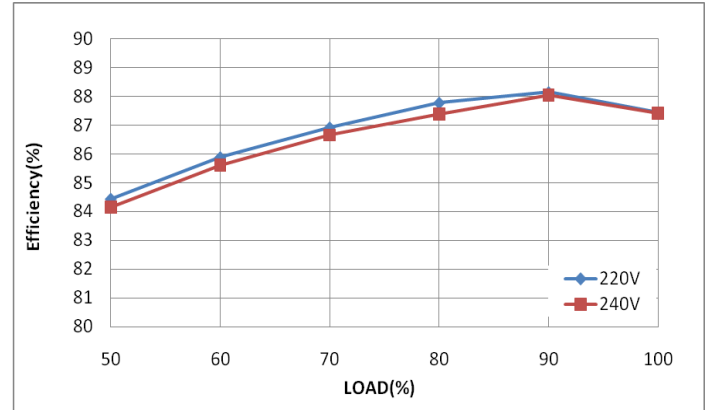

Power Factor Characteristics

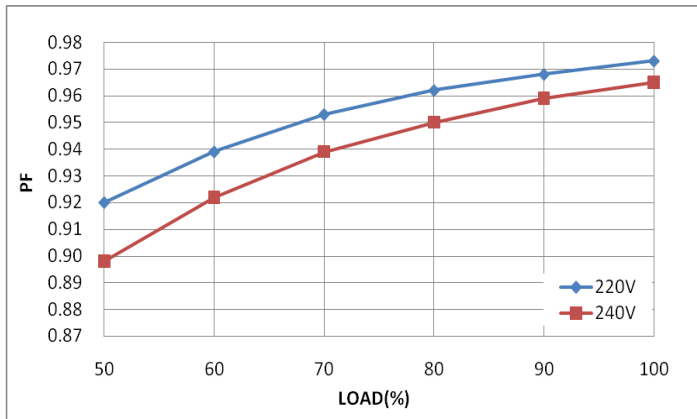

THD vs. Load

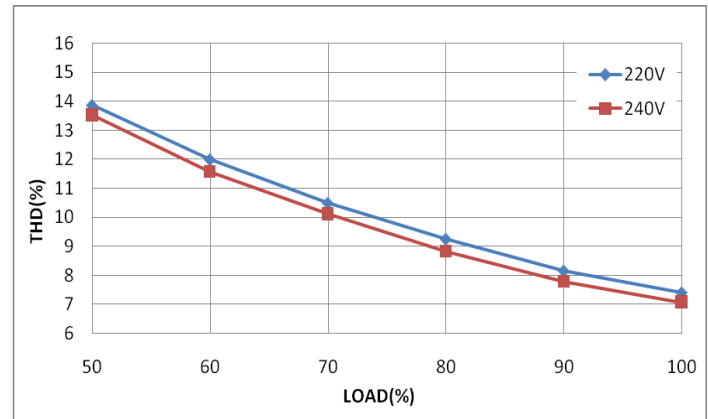

■Operating window

